

FTL-98ETS

90 IPERLOTUS ELECTRIC GRIDDLE

Electric Fry-top smooth chromed griddle
SUPERCHROME (Moca Approved), on open
cabinet, plate cm.76x68 - 2 cooking areas
(included 1 Head end filler strip mod.TPA-9)



Construction - Fabricated using CrNi 18/10 AISI 304 grade Stainless Steel Scotch-Brite Satin polish Finish, incorporating 2mm thick worktop, rounded edges, chromed details and rear splash back. Knobs with waterproof grades IPX5. Model - Professional Electric Griddle, Smooth, Ribbed or 50 / 50, Normal or Chrome, on open cabinet. Normal Plate in FE430B Steel and Chrome in FE510C Steel. Normal or Chrome plate in chrome-molibdeno, 20mm thick, for model FT-912/916. Double thermostat, operating and safety. High durability and rapid heat up. 50 - 300degC control, Removable liquid containers. Maintenance - All serviceable parts are accessible by the easy removal of front control panel. Fittings - Appliance is supplied with adjustable feet. Doors not included.

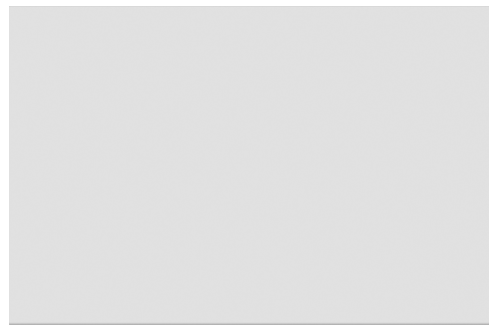

ITALIAN CULINARY ART

The pictures are purely representative. The manufacturer reserves the right to modify the technical data and models without previous notice.

FTL-98ETS

90 IPERLOTUS
ELECTRIC GRIDDLE

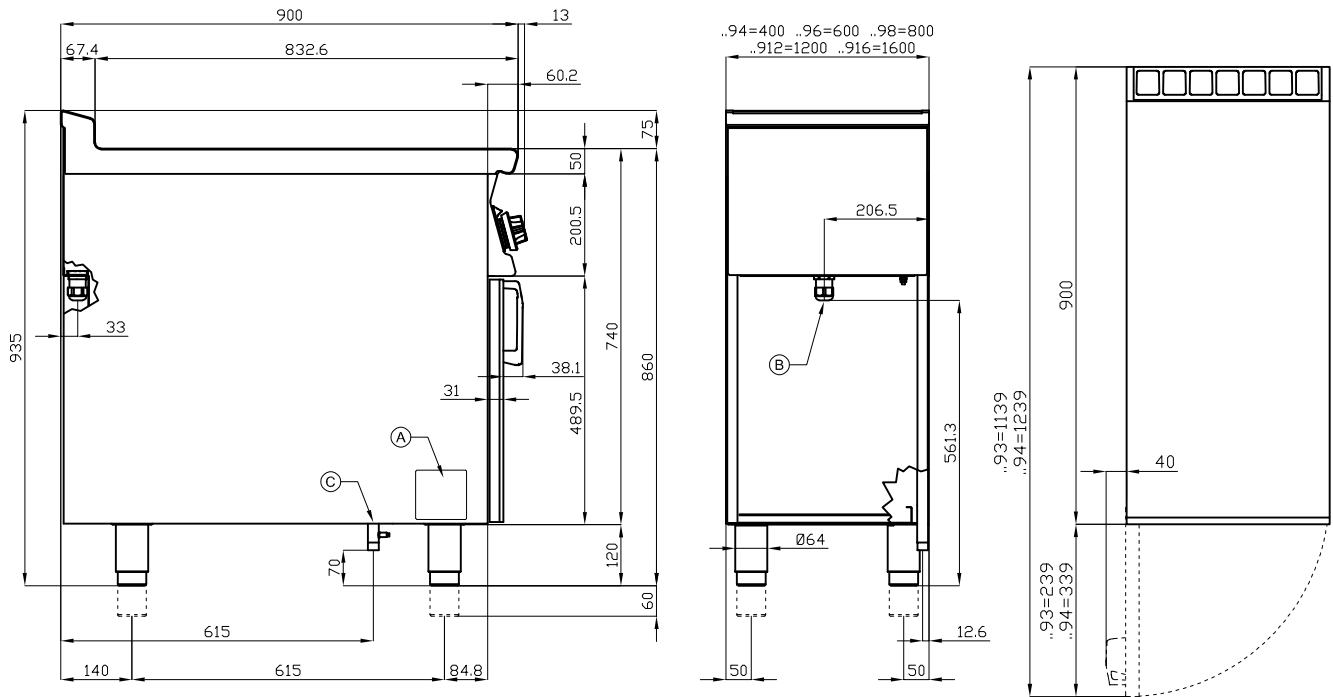

A	Data plate	B	Electrical connection
---	------------	---	-----------------------

MODEL: FTL-98ETS
 DIMENSIONS: cm. 80x 90x 90h
 ELECTRIC POWER: 15 kW
 VOLTAGE: 400V~3N
 FREQUENCY: 50/60 Hz

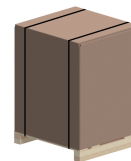

kg: 126
 m³: 0.894
 mm: 830x970x1110

BUY LOTUS BUY ITALY

The pictures are purely representative. The manufacturer reserves the right to modify the technical data and models without previous notice.



LOTUS S.P.A. Via Calmaor, 46
 31020 San Vendemiano(TV) - Italy
 Tel. + 39 0438 778020 / 778468
 Fax + 39 0438 778277
 www.lotuscookers.it - lotus@lotuscookers.it